

# National Rock & Mineral Show

**Marlborough**  
**29 September to 2 October 2016**



# Competition Schedule

## INDEX

	<u>PAGE</u>
Trophies to be Competed For .....	3
Duties of Competitors .....	6
Schedule of Competition Classes .....	7
Division One	
Tumbled Stones & Preforms .....	9
Cabochons & Freeforms .....	11
Slabs, Butt Ends, Blocky Specimens .....	13
Domed Butt Ends, Petrified Wood, Spheres .....	13
Intarsia, Mosaic & Unusual Gemstone Article .....	15
Carving .....	17
Faceted Stones .....	19
Division Two	
Jewellery & Metalsmithing .....	21
Division Three	
Minerals .....	28
Division Four	
Fossils .....	31
Division Five	
Novice .....	33
Division Six	
Educational Case .....	35
Appendix A – Cabinet Specifications .....	37
Appendix B – Mineral Books .....	38
Appendix C – Diagrammatic Representation of a Standard Cabochon .....	39
Appendix D – Faceting Diagrams .....	40-44

## TROPHIES TO BE COMPETED FOR

**1 THE KEN ALLEN TROPHY** for the inter-club competition.

Donated by Mary Allen from the Canterbury Mineral & Lapidary Club.

- a The case must tell a story and have an educational content.
- b The case will be judged by a panel of three judges, one of whom has experience in education (lecturer or schoolteacher).

Points Allocation

Educational and story content	60
Presentation of materials	15
General attraction	15
Originality of idea	<u>10</u>
TOTAL	<u>100</u>

*Space Allocation: Full cabinet size as defined in Appendix A  
Entry Form required*

**2 THE POINTS TROPHY** for the overall winner of the most points.

Donated by the Auckland Geological & Lapidary Club Inc.

Points Allocation

1st place	5 points
2nd place	3 points
3rd place	1 point

**3 THE ROCKHUNTER CUP** for the best New Zealand fossil.

Donated by Marie and Keith Boese.

**4 THE CHRIS ANGWIN TROPHY** for the best entry in carved New Zealand nephrite jade in any class.

Donated by the New Zealand Mineral Club.

**5 THE LEVENES TROPHY** for the person gaining the most points in the mineral sections.

Donated by the South Auckland Rock & Mineral Club.

*Assessment as for The Points Trophy*

**6 THE HOPE CHISHOLM TROPHY** for the best mineral specimen in the mineral sections of the Show, seen without the aid of magnification.

Donated by the New Zealand Mineral Club.

**7 THE MEL SAYWELL TROPHY** for the person gaining the most points in the cabochon sections.

Donated by Taranaki Lapidary & Mineral Club.

*Assessment as for The Points Trophy*

**8 THE RINGER MEMORIAL TROPHY** for excellence in hand-crafted jewellery.

Donated by the Whangarei Rock & Gemstone Club.

This trophy will be awarded to the person who gains the highest pointed entry, in the classes for hand-crafted metal jewellery without stones or organic material.

(Sub-section O4, Classes 59 & 60).

- 9 THE LLOYD CLAYDON MEMORIAL TROPHY** for the Club with the most entries from it's members.  
Donated by the North Shore Rockhounds Club.  
The National Association will supply the exhibition organisers with a list of clubs giving membership numbers. This will enable the organisers to determine the number of entries as a percentage of each club. The club with the highest percentage wins.
- 10 THE EDITH GEDDES MEMORIAL TROPHY** for the best specimen in Sections F & G.  
Donated by the Hauraki Rock & Mineral Club.
- 11 THE 1990 TOURIST DIAMOND JUNIOR TROPHY** for the highest number of points accumulated by a junior competitor.  
Donated by Rotorua, Putararu and Taupo Clubs.
- 12 THE TURNER TROPHY** for the best specimen in Section H (Petrified Wood).  
Donated by Nancy Topp.
- 13 TAURANGA GEM & MINERAL CLUB TROPHY** for best New Zealand mineral specimen in Show.  
Donated by Tauranga Gem & Mineral Club.
- 14 MAGNOLIA MINERAL CUP** for best overseas mineral in all sections.  
Donated by the Pawson Family.
- 15 TAURANGA GEM & MINERAL CLUB TROPHY** for best faceted stone in Class 41.  
Donated by Tauranga Gem & Mineral Club.
- 16 REG CLAPPERTON MEMORIAL TROPHY** for highest pointed entry in the Specified Cabochon Class.  
Donated by the Hawke's Bay Gemstone & Lapidary Club.
- 17 WEST COAST GEM & MINERAL CLUB INC EDITORS TROPHY** for the best newsletter/magazine during the year.  
Donated by West Coast Gem & Mineral Club.
- 18 OWEN START MEMORIAL TROPHY** for excellence in tumbled stones.  
Donated by Pam Start.  
This trophy will be awarded to the person who gains the highest pointed entry in the classes for tumbled stones in Section A, Classes 1 & 2.
- 19 THE TAUMARUNUI AMMONITE TROPHY** for the best ammonite in Show in Section V.  
Donated by the Taumaranui Rock Club.
- 20 THE TAUMARUNUI CHALLENGE TROPHY** for the best Junior fossil cabinet in Section V.  
Donated by the Taumaranui Rock Club.

**21 THE DENNIS TODD TROPHY** for the best piece of Curnow Road material in any class in Divisions One & Two.

Donated by Dennis Todd of the Palmerston North Rock & Mineral Club.

**This must be labelled by the competitor “Curnow Road”. To be eligible, the entry must be accompanied by an original digging receipt, which is non-returnable and can only be used once.**

Digging receipts can be obtained by either –

- a Paying a digging fee to the Whangarei Club.
- b Purchasing Curnow Road material at a National Show, from the Whangarei Club, where a digging receipt will be issued for each piece of material purchased.

**22 THE RAY KILSBY MEMORIAL TROPHY** for the competitor with the highest accumulated points in the carving classes using material with a hardness over 5 (Classes 24, 25, 26, 28 and 31).

Donated by the Taranaki Lapidary & Mineral Club.

*Assessment as for The Points Trophy*

## **DUTIES OF COMPETITORS**

*(Excerpt from Competition Rules for National Exhibition Classes)*

No competitive exhibit shall exceed the dimensions laid down in the Schedule.

All entries shall be the competitor's own work in the terms of the Schedule.

All labelling shall be the duty of the exhibitor –

- a Each entry shall be accompanied by a white card (50mm x 25mm) bearing the competitor's name and club name on one side and the Section and Class numbers on the other. The entry number is to be added to this side at the time of placing.
- b Another label containing other information such as type of material, location found, or name of entry must be included, only large enough for information.

The competitor shall advise on their Entry Form the means of delivery and return of their entry.

Where, owing to the absence in person of the competitor or the competitor's representative from the exhibition, it is desired that the Steward shall set out the exhibit, explicit directions shall be given by the competitor but the Steward shall not be held to blame for unwittingly misinterpreting these.

The Steward shall not be called upon to spend what may be considered undue time or expense on a directed arrangement. Arrangements to be made by stewards shall be simple.

Special requirements for lighting or other uses of electric power shall be at the discretion of the exhibition organisers and the competitor shall have the responsibility of –

- a Asking in plenty of time for his requirements to be met, if possible.
- b Ensuring that his installation meets safety requirements.

The competitor will accept all provisions concerning damage or loss as laid out in these rules.

All exhibitors will accept the Judges' rulings as final.

No exhibit tabled may be removed until the exhibition is declared closed by the organisers and it should be removed promptly by the exhibitor or, in his absence and at his direction, by his representative who should be provided with credentials.

Where stewards are required to dispatch exhibits to owners at the close of the exhibition all entries must include named containers/packaging materials, self-addressed return packaging and postage. The competitor shall be liable for any extra costs involved on account of under-estimation on his part.

No competitor shall enter for NZ National Competition any identical exhibit which has already won an award in a previous NZ National Competition.

For the purposes of the Lloyd Claydon Memorial Trophy, the competitor must list all the NZ affiliated clubs to which he or she belongs on his or her Entry Form.

**A competitor should acquaint himself with the Competition Rules for National Exhibition Classes as provided by the Secretary of his club.**

## **SCHEDULE OF COMPETITION CLASSES**

There is no limit to the number of classes for which any one person may enter, but only one entry per person in any one class may be made.

Junior divisions are available in all classes for "*one who has not reached the age of sixteen years by 1 January 2016*". On the Entry Form headings are to be the same as shown in this Schedule except that they are to be prefixed by the letter "J" to denote Junior, eg Class J81.

Competitors must comply strictly with all rules, numbers and maximum size restrictions as shown in this Schedule. Infringements may result in disqualification.

All material must be correctly labelled and identified. Space allocations for Division One and Two is indicated by xxx mm x xxx mm. Divisions Three and Four are either half or full cabinet as indicated.

## **DIVISION ONE: LAPIDARY**

All entries will be placed on a background of plain white fabric. This requirement does not preclude the use of stands used only to display specimens. This concession will ensure entries of colouring similar to the background material need not be disadvantaged.



## SECTIONS A, B & N1 – TUMBLED STONES & PREFORMS

### Tumbled Stones

The material to be used for tumbled stones can be natural or hammer broken, then tumble ground and polished.

#### Points Allocation for Tumbled Stones

Aesthetic appeal	10
Polish	25
Freedom from pits and surface scratches	20
Freedom from flaws and cracks	20
Variety of material	10
Difficulty of material	10
Labelling	<u>5</u>
TOTAL	<u>100</u>

### Tumbled Preforms

The competitor is given the option of exercising control over the final shape of each stone which may be sawn and hand ground but then must be tumble ground and polished. Each stone should show evidence of being ground by tumbling.

#### Points Allocation for Tumbled Preforms

Aesthetic appeal	10
Polish	25
Freedom from flaws	30
Design	20
Difficulty of material	10
Labelling	<u>5</u>
TOTAL	<u>100</u>

**SECTION A – TUMBLED STONES**

Each Class – six specimens

Stone, natural or hammer broken then tumble ground and polished. No specimen should be able to pass through a 20mm diameter hole.

		<u>Space Allocation</u>
<b>Class 1</b>	NZ origin	200mm x 200 mm
<b>Class 2</b>	Any origin	200mm x 200 mm

**SECTION B – TUMBLED PREFORMS**

Each Class – five specimens

Stone, preformed by saw and/or grinding, then tumble ground and polished.

		<u>Space Allocation</u>
<b>Class 3</b>	NZ origin	200mm x 200mm
<b>Class 4</b>	Any origin	200mm x 200mm

## SECTIONS C, D & E – CABOCHONS & FREEFORMS

### Cabochons

The definitions of the different types of cabochons are associated with each class in the Schedule and must be strictly adhered to. All entries in Sections C, D and E are to be made by hand with no mechanical aids, other than the standard templates required for Sections C and D.

#### Points Allocation for Standard and Fancy Cabochons

<b>Dome:</b> Polish	15
Girdle	5
Flats and scratches	10
Pits and fractures	10
<b>Back:</b> Polish	15
Bevel	5
Scratches, pits and fractures	5
Aesthetic appeal	5
Symmetry	15
Difficulty of material (size accuracy in Class 7)	10
Labelling	<u>5</u>
TOTAL	<u>100</u>

### Hand-held Freeform

The definition of a hand-held freeform is “A stone which can be used for jewellery and is cut freehand without the aid of faceting machinery. Surfaces can be bevelled, straight or curved. Edges must be clearly defined and all surfaces polished”.

#### Points Allocation for Hand-held Freeforms

Polish	25
Flats and scratches	15
Pits and fractures	15
Aesthetic appeal	15
Design	15
<i>(allowance should be made for inside curves)</i>	
Difficulty of material	10
Labelling	<u>5</u>
TOTAL	<u>100</u>

**SECTION C – STANDARD CABOCHON**

Class 5 and 6 – three specimens  
Class 7 – one specimen

The definition of a Standard Cabochon is “Any cabochon of circular or elliptical shape having a symmetrically curved domed top with a polished flat back. It must have a back bevel that must not be more than 1/5th the overall height of the cabochon and a distinct girdle line. A top setting edge is optional”. (See Appendix C for diagrammatic specification of a standard cabochon)

		<u>Space Allocation</u>
<b>Class 5</b>	NZ origin	200mm x 200mm
<b>Class 6</b>	Any origin	200mm x 200mm
<b>Class 7</b>	A single cabochon, material and size to be named by the Host Club. Points for “difficulty of material” will be replaced by “accuracy” of size.”	
	<u>The judge must use a Vernier, Engineer’s calliper or dial gauge to measure the dimensions of the stones, plus or minus 0.5mm allowance to be made before points are deducted.</u> Material must be readily available to all competitors.	
	<b>2016: NZ Fossil Shells 30 mm x 40 mm</b>	

Rock slices are available from Marlborough Rock and Mineral Club at \$5 plus postage

**SECTION D – FANCY CABOCHON**

Each Class – three specimens

A cabochon shape other than “Standard”, otherwise the same definition as for Section C.

		<u>Space Allocation</u>
<b>Class 8</b>	NZ origin	200mm x 200mm
<b>Class 9</b>	Any origin	200mm x 200mm

**SECTION E – HAND-HELD FREEFORM**

Three specimens

		<u>Space Allocation</u>
<b>Class 10</b>	Any origin	200mm x 200mm

## **SECTIONS F, G, H, I & J – SLABS, BUTT ENDS & BLOCKY SPECIMENS DOMED BUTT ENDS, PETRIFIED WOOD, SPHERES**

### **Slab**

A slab is a slice of rock of any thickness with parallel or nearly parallel faces. For the purposes of this competition only one face needs to be polished and it is that face which will be judged.

### **Butt End**

A butt end is a blocky piece of rock with one cut and polished face.

### **Blocky Specimen**

A blocky specimen is a blocky piece of rock with more than one cut face with the faces neither parallel nor nearly parallel. For the purposes of this competition only one face needs to be polished and it is that face which will be judged.

#### Points Allocation for Slabs, Butt Ends and Blocky Specimens

Flatness	15
Edges	15
Face polish	25
Difficulty of material	15
Labelling	5
Aesthetic appeal	<u>25</u>
TOTAL	<u>100</u>

### **Domed Butt End**

As above for a butt end but with one face polished in a dome. Measurements for Classes 17 and 18 are to be made through the stone, ie diameter, not around the curve of the dome.

#### Points Allocation for Domed Butt Ends

Quality of dome	25
Edges	15
Face polish	25
Difficulty of material	10
Labelling	5
Aesthetic appeal	<u>20</u>
TOTAL	<u>100</u>

### **Sphere**

A sphere is a perfectly round solid geometric shape.

#### Points Allocation for Spheres

Polish	20
Freedom from flats and scratches	15
Freedom from pits and fractures	15
Spherical accuracy	15
Difficulty of material	10
Labelling	5
Aesthetic appeal	<u>20</u>
TOTAL	<u>100</u>

### **SECTION F – SLABS**

Polished one face, three specimens, any origin

		<u>Space Allocation</u>
<b>Class 11</b>	No dimension of polished face is to exceed 80mm	250mm x 250mm
<b>Class 12</b>	One dimension of polished face is to exceed 80mm	400mm x 300mm

### **SECTION G – BUTT ENDS & BLOCKY SPECIMENS**

Polished one face, three specimens, any origin

		<u>Space Allocation</u>
<b>Class 13</b>	No dimension of polished face is to exceed 80mm	250mm x 250mm
<b>Class 14</b>	One dimension of polished face is to exceed 80mm	400mm x 300mm

### **SECTION H – A SELECTION OF POLISHED PETRIFIED WOOD IN SLAB, BUTT END OR BLOCKY SPECIMEN FORM**

Polished one face, three specimens, any origin

		<u>Space Allocation</u>
<b>Class 15</b>	No dimension of polished face is to exceed 80mm	250mm x 250mm
<b>Class 16</b>	One dimension of polished face is to exceed 80mm	400mm x 350mm

### **SECTION I – DOMED BUTT ENDS**

Polished one face, three specimens, any origin

		<u>Space Allocation</u>
<b>Class 17</b>	No dimension of polished face, measured through the stone, is to exceed 80mm	250mm x 250mm
<b>Class 18</b>	One dimension of polished face, measured through the stone, is to exceed 80mm	400mm x 350mm

### **SECTION J – SPHERES**

Polished, one specimen

		<u>Space Allocation</u>
<b>Class 19</b>	Diameter of sphere must be a minimum of 50mm to a maximum of 100mm. NZ origin	200mm x 200mm
<b>Class 20</b>	Diameter of sphere must be a minimum of 50mm to a maximum of 100mm. Any origin	200mm x 200mm

## SECTION K – INTARSIA, MOSAIC & UNUSUAL GEMSTONE ARTICLE

### Intarsia

Intarsia consists of any stone, shaped and fitted together to eliminate gaps, flat lapped and polished so as to appear as one continuous surface of stone.

### Unusual Gemstone Article

Entries are for a single item that does not fit into any other category in the Schedule.

#### Points Allocation for Intarsia & Unusual Gemstone Article

Design	20
Workmanship	65
Difficulty of material	<u>15</u>
TOTAL	<u>100</u>

### Mosaic

Mosaics are made from loose fitting, usually square or rectangular tiles or tumble polished stones of different colours or combinations, put together to form a design, usually a picture, and grouted or fitted together close enough to do without grout, but not flat lapped and polished.

#### Points Allocation for Mosaic

Design	20
Workmanship	65
Use of material	<u>15</u>
TOTAL	<u>100</u>

**SECTION K – INTARSIA, MOSAIC & UNUSUAL GEMSTONE ARTICLE**

Each Class – one item only

		<u>Space Allocation</u>
<b>Class 21</b>	Intarsia	400mm x 300mm
<b>Class 22</b>	Mosaic	400mm x 300mm
<b>Class 23</b>	Unusual Gemstone Article	400mm x 300mm



## SECTION L – CARVING

### **In the Round**

Is a free-standing item that is carved all the way around. It may have a base.

### **In the Flat**

Is an item that is carved on one side only and can only be viewed in proportion from the carved side.

### Points Allocation

Aesthetic appeal	10
Design	30
Difficulty of material	10
Workmanship	<u>50</u>
TOTAL	<u>100</u>

## SECTION L – CARVING

		<u>Space Allocation</u>
<b>Class 24</b>	Carved single item, pendant, nephrite jade only	300mm x 200mm
<b>Class 25</b>	Carved single item, pendant, any stone other than nephrite jade	300mm x 200mm
<b>Class 26</b>	Single item of stone, no cement or joins, carved in the flat. Hardness 5 and above	300mm x 300mm x 300mm
<b>Class 27</b>	Single item of stone, no cement or joins, carved in the flat. Hardness under 5	300mm x 300mm x 300mm
<b>Class 28</b>	Single item of stone, no cement or joins, carved in the round or sculpture. Hardness 5 and above	300mm x 300mm x 300mm
<b>Class 29</b>	Single item of stone, no cement or joins, carved in the round or sculpture. Hardness under 5	300mm x 300mm x 300mm
<b>Class 30</b>	Carved single item, multiple stones with cement and/or joins, other materials permissible. Any hardness	300mm x 300mm x 300mm
<b>Class 31</b>	Related carved stone items forming a set, other materials permissible, with cement and/or joins. Hardness 5 and above	300mm x 300mm x 300mm
<b>Class 32</b>	Related carved stone items forming a set, other materials permissible, with cement and/or joins. Hardness under 5	300mm x 300mm x 300mm
<b>Class 33</b>	Single item, carved pendant, any animal-based material	300mm x 200mm
<b>Class 34</b>	Carving, other than pendant, any animal-based material	300mm x 200mm
<b>Class 35</b>	Single item, scrimshaw	300mm x 300mm x 300mm
<b>Class 36</b>	Any carved item with a base, of any material, which adds to the aesthetic appeal or is part of the overall design	300mm x 300mm x 300mm

## SECTION M – FACETED STONES

Materials to be used in Classes 37, 38, 39, 40 and 41 will be the choice of the club hosting the competitions, so that all competitors are cutting the same material. The Host Club when selecting materials should take care and not choose rare and costly rough and hence prevent some competitors from entering the competitions.

### Size of Materials

Natural material – Width not less than 5mm

Man-made material – Width not less than 8mm

### Points Allocation

Overall appearance	15
Table parallel to girdle	5
Meets	15
Facets true	5
Facet edges sharp	10
Girdle too wide	5
Girdle uniform	5
Absence of scratches	5
Absence of chips	5
Absence of flaws	10
Polish	<u>20</u>
TOTAL	<u>100</u>

## SECTION M – FACETED STONES

Each Class – one specimen

Classes 37-41 – See Appendix D for cutting diagrams

		<u>Space Allocation</u>
<b>Class 37</b>	<u>Standard Round Brilliant Cut</u> (Standard Cut) 3 rows of facets on crown 2 rows of facets on pavilion <u>Note</u> Host Club to nominate either continuous or faceted girdle Material: <b>2016: Cubic Zirconia</b> Girdle: <b>Faceted</b>	150mm x 150mm
<b>Class 38</b>	<u>Emerald Cut with cut corners</u> (Standard Cut) 3 rows of facets on crown 3 rows of facets on pavilion Faceted girdle Material: <b>2016: Quartz</b>	150mm x 150 mm
<b>Class 39</b>	<u>Eight-Sided Brilliant</u> (Standard Cut) 3 rows of facets on crown 3 rows of facets on pavilion Faceted girdle Material: <b>2016: Garnet</b>	150mm x 150mm
<b>Class 40</b>	<u>Modified Standard Cut</u> Must have a table, girdle, crown and pavilion Any other stone that differs from a standard cut comes into this section Material: <b>2016: Quartz</b> Cut: <b>Fiorello</b>	150mm x 150mm
<b>Class 41</b>	<u>Fancy Cut</u> Is a cut which is lacking in one or more of the following: table, crown, girdle, pavilion, but at least 50% must be faceted <u>Note</u> Host Club may or may not specify a particular cut Material: <b>2016: Topaz</b> Cut: <b>Parklane</b>	150mm x 150mm
<b>Class 42</b>	<u>Cutters Choice</u> There are no restrictions, other than the general size restrictions in this class <u>Note</u> cutting diagram must be submitted with this class	150mm x 150mm

## **DIVISION TWO: JEWELLERY & METALSMITHING**

The aim of the Jewellery Sections is to display items of practical use, ie jewellery is normally expected to be worn as an item of adornment, and the item entered should reflect this fact.

All items entered will be displayed on blue fabric. All work will be the competitor's own except where allowed for in the Schedule. Section N provides for commercial mounts and/or findings, but Section O has classes where unworked material, or material purchased, may be set in handcrafted mount and/or finding WHICH IS THE COMPETITOR'S OWN WORK. Where catches or screws are used and material other than the competitor's own is used, this MUST be noted on the accompanying label.

Each sub-section will consist of 2 or 3 classes. A set will consist of more than one piece. A pair of earrings or cuff links would be regarded as one piece in a set, but they should not be entered in the class for a single piece, except in sub-sections N1 and N2 where provision has been made for this.

Where there are lists of materials in particular classes the fact that a material is not listed does not exclude it from entry and shall not be the basis of it's disqualification providing it is of a similar type, ie a metal in the metal classes, an organic item in the organic classes, or an unworked item in the unworked material class.

When judging an entry the judging guideline for any particular type of work is applicable to the judging of that item, ie in Section N Tumbled Stones Only Class 43, the stone would be judged according to the tumbled stones guideline. Whereas in Class 49, Faceted Stones Only, the faceting guidelines would be applicable.

**SECTION N – JEWELLERY WITH COMMERCIAL CHAINS, MOUNTS AND/OR FINDINGS (OR NON-COMMERCIAL CHAINS, MOUNTS AND/OR FINDINGS NOT WORKED BY THE COMPETITOR)**

All work on the stone(s) or organic material must be the competitor's own.

Points Allocation

Aesthetic appeal	20
Polish	20
Workmanship (stone only)	25
Design	20
Difficulty of material	10
Labelling	<u>5</u>
TOTAL	<u>100</u>

### SECTION N1 – TUMBLLED STONES ONLY

The judge is looking at the whole entry not only the quality of the stone, but also how the stones blend in with the setting and it's suitability for the purpose of jewellery. This is the class to use small high quality stones. See Division One, Sections A & B for further guidelines.

		<u>Space Allocation</u>
<b>Class 43</b>	Single piece, one stone only	150mm x 200mm
<b>Class 44</b>	Single piece, more than one stone ( <i>This includes cuff links and earrings</i> )	150mm x 200mm
<b>Class 45</b>	One set	150mm x 200mm

### SECTION N2 – CUT STONES ONLY

Cut free-hand without the aid of faceting machinery. Stones may be tumbled or lap finished.

		<u>Space Allocation</u>
<b>Class 46</b>	Single piece, one stone only	150mm x 200mm
<b>Class 47</b>	Single piece, more than one stone ( <i>This includes cuff links and earrings</i> )	150mm x 200mm
<b>Class 48</b>	One set	150mm x 200mm

### SECTION N3 – FACETED STONES ONLY

		<u>Space Allocation</u>
<b>Class 49</b>	Single piece	100mm x 100mm
<b>Class 50</b>	One set	300mm x 300mm

### SECTION N4 – HANDCRAFTED ORGANIC ONLY

This class provides for the use of any worked organic material.

		<u>Space Allocation</u>
<b>Class 51</b>	Single piece	150mm x 200mm
<b>Class 52</b>	One set	300mm x 300mm

## SECTION O – JEWELLERY WITH HANDCRAFTED METAL CHAINS, MOUNTS AND/OR FINDINGS

All metal work must be the competitor's own. Catches and screws may be ready-made but this must be noted on the accompanying label. All work on the stone(s) or organic material must be the competitor's own, except where stated in sub-sections O5 & O6.

### Points Allocation

Aesthetic appeal	20
Technical skill and creativity	30
Workmanship	25
Finish	20
Labelling	<u>5</u>
TOTAL	<u>100</u>



## **SECTION 01 – CUT STONES ONLY**

Cut free-hand without the aid of faceting machinery. Stones may be tumbled or lap finished.

		<u>Space Allocation</u>
<b>Class 53</b>	Single piece	150mm x 200mm
<b>Class 54</b>	One set	300mm x 300mm

## **SECTION 02 – FACETED STONES ONLY**

		<u>Space Allocation</u>
<b>Class 55</b>	Single piece	100mm x 100mm
<b>Class 56</b>	One set	300mm x 300mm

## **SECTION 03 – HANDCRAFTED ORGANIC ONLY**

		<u>Space Allocation</u>
<b>Class 57</b>	Single piece	150mm x 200mm
<b>Class 58</b>	One set	300mm x 300mm

## **SECTION 04 – JEWELLERY WITHOUT STONES OR ORGANIC MATERIAL**

		<u>Space Allocation</u>
<b>Class 59</b>	Single piece	200mm x 200mm
<b>Class 60</b>	One set	300mm x 300mm

## **SECTION 05 – JEWELLERY WITH STONE(S) OR ORGANIC MATERIAL NOT WORKED BY COMPETITOR, eg fossil, crystal, bought stones**

In this sub-section the workmanship on the stone will not be judged, however how it is set into the handcrafted metal will be judged.

		<u>Space Allocation</u>
<b>Class 61</b>	Single piece	150mm x 200mm
<b>Class 62</b>	One set	300mm x 300mm

## **SECTION 06 – ANY HANDCRAFTED METAL JEWELLERY**

**that is not covered in sub-sections O1-O5, eg jewellery with a combination of worked and unworked stones or organic material in same item**

Any unworked stones or organic material must be noted in the accompanying label.

		<u>Space Allocation</u>
<b>Class 63</b>	Single piece	150mm x 200mm
<b>Class 64</b>	One set	300mm x 300mm

## SECTION P – METALSMITHING, NOT JEWELLERY

### Points Allocation

Aesthetic appeal	20
Technical skill and creativity	30
Workmanship	25
Finish	20
Labelling	<u>5</u>
TOTAL	<u>100</u>

**SECTION P – METALSMITHING, NOT JEWELLERY**

<b>Class 65</b>	Single piece or set, with or without stone(s) or organic material	<u>Space Allocation</u> 300mm x 300mm
-----------------	---	--

## DIVISION THREE: MINERALS

The aim of the mineral classes is to present the best in minerals so as to inform both the knowledgeable collectors as well as the novices, and to please other visitors to the Show. The minerals themselves must be the focus of the displays, but with a pleasing presentation to enhance the aesthetic appeal of the display and to hold the interest of the viewer.

All specimens must be the competitor's own.

Cabinet size (half and full) is defined in Appendix A.

Please specify on Entry Form whether a half or full cabinet is required for Section U.

In "Self-Collected" classes the minerals must have been collected in the field by the competitor.

In "Assorted" classes, each mineral can only be shown once, eg you can't have amethyst and citrine in the same entry as both are quartz. Minerals must be either NZ or Overseas but not both together.

In "One Family" classes, you can show similar specimens, eg all fluorite or varieties of quartz or all carbonates. "One Family" can also mean minerals from a single location (eg Martha Mine) and repeat minerals are allowed.

Display cases will be fully lined with white fabric. This does not preclude competitors using other backgrounds and display materials. The sections within this Division are defined by the size of specimens. Some definitions follow to make clear what is intended.

### SIZE OF SPECIMENS

#### **Micromounts**

All specimens must be permanently mounted in a box not exceeding the dimensions of a 25mm (1") cube. They must require magnification and illumination for proper observation.

#### **Thumbnails**

All specimens must be small enough to fit into a 30mm cube.

#### **Miniature Hand size**

All specimens must be too large to fit into a 30mm cube but must be small enough to fit into a 80mm cube.

#### **Cabinet and Museum Size**

All specimens must be larger than will fit into a 80mm cube.

It is recommended that competitors use a cube of rigid material to gauge the size of their specimens and not rely upon the use of a ruler.

In sections other than the Micromounts section, all crystals must be large enough to be observed without magnification.

## SECTIONS Q, R, S, T & U – MICROMOUNTS, THUMBNAILS, MINIATURE HANDSIZE, CABINET & MUSEUM SIZE

Points Allocation - this shall be broken into two parts

<b>A</b>	<b>Presentation:</b>	10
	Overall impact	
	Emphasis clearly on minerals	
	A well-balanced case or display	
	Use of a theme	
	Uniformity and care in printing of labels	
	Arrangement of specimens	
	Mineral displayed to advantage	
	Co-ordination of background	
	Legibility of labels	
	Size of labels	

Note The label should not overwhelm the specimens. Too much information on the labels is just as bad as too little. If photographs are used to enhance the presentation of an entry in the Micromount classes, and they are not the work of the competitor, the photographer must be acknowledged.

<b>B</b>	<b>Specimens:</b>	
	Content of Label	
	Mineral name	2
	Chemical formula	1
	Locality	2
	Quality of the Specimen	
	Aesthetic appeal, balance and beauty of specimen, including orientation on matrix or mount (if applicable)	25
	Freedom from chips, cracks, flaws, bruises and dirt (and glue if used in mounting)	25
	Size, shape, form, crystallinity and colour in relation to the species (taken into account will be class size)	<u>35</u>
<b>TOTAL</b>		<u>100</u>

If a mineral is in the incorrect family in the “One Family” classes, that mineral will score no points.

In all classes, if the judge decides that a mineral conflicts with the data on it's label, that mineral will score no points.

It is recommended that the convenors of the Show ensure there are sufficient judges for the number of entries.

**Note for Judges** Each mineral and the contents of its accompanying label are judged out of a total of 90 points. The total points accumulated are then divided by the number of specimens, giving the average. A scoring sheet will be provided to make the task as simple as possible.

### **SECTION Q – SINGLE MINERAL**

One specimen only

- Class 66** A single specimen of a mineral, the species, origin and size (excluding micromounts) to be decided upon each year by the Host Club. The Host Club may put a restriction on size due to available display space or to make the competition more even. The mineral species chosen must be readily available to all competitors.  
**2016: NZ Calcite - 80 mm to 300 mm**

### **SECTION R – MICROMOUNTS**

Each Class – six to ten specimens

- |                 |   | <u>Space Allocation</u> |
|-----------------|---|-------------------------|
| <b>Class 67</b> | NZ minerals, assorted or one family       | Half Cabinet            |
| <b>Class 68</b> | Overseas minerals, assorted or one family | Half Cabinet            |

### **SECTION S – THUMBNAILS**

Each Class – six to ten specimens

- |                 |   | <u>Space Allocation</u> |
|-----------------|---|-------------------------|
| <b>Class 69</b> | NZ minerals, assorted or one family       | Half Cabinet            |
| <b>Class 70</b> | NZ minerals, self collected               | Half Cabinet            |
| <b>Class 71</b> | Overseas minerals, assorted or one family | Half Cabinet            |
| <b>Class 72</b> | Overseas minerals, self collected         | Half Cabinet            |

### **SECTION T – MINIATURE HANDSIZE**

Each Class – six to ten specimens

- |                 |   | <u>Space Allocation</u> |
|-----------------|---|-------------------------|
| <b>Class 73</b> | NZ minerals, assorted or one family       | Half Cabinet            |
| <b>Class 74</b> | NZ minerals, self collected               | Half Cabinet            |
| <b>Class 75</b> | Overseas minerals, assorted or one family | Half Cabinet            |
| <b>Class 76</b> | Overseas minerals, self collected         | Half Cabinet            |

### **SECTION U – CABINET AND MUSEUM SIZE**

Each Class – six to ten specimens

- |                 |   | <u>Space Allocation</u> |
|-----------------|---|-------------------------|
| <b>Class 77</b> | NZ minerals, assorted or one family       | Half or Full Cabinet    |
| <b>Class 78</b> | NZ minerals, self collected               | Half or Full Cabinet    |
| <b>Class 79</b> | Overseas minerals, assorted or one family | Half or Full Cabinet    |
| <b>Class 80</b> | Overseas minerals, self collected         | Half or Full Cabinet    |

## DIVISION FOUR: FOSSILS

The aim is for high quality and well-presented fossils. We must show that fossils are more than curious or beautiful objects since they give us valuable information of past life and environments. Displays of unthemed fossils are not acceptable. Labelling and informative material are important to explain what the species tell us about their changes or environment or age or any other aspect the entrant considers suitable. This approach to fossils will make the exhibits more interesting to the public.

Cabinet size (half and full) is defined in Appendix A.  
Please specify on Entry Form whether a half or full cabinet is required.

### Points Allocation

<b>Fossil(s) themselves, quality and rarity:</b>	60
Judge to weigh perfect specimens of common fossils against the possibly imperfect specimens of rare fossils	
<b>Basic information:</b>	
Fossil identification and name	
	10
Locality (map reference not required)	
	2
Age (eg, Mesozoic, Jurassic or Tertiary Miocene)	
	2
<b>Research:</b>	10
An explanation of the significance of the fossils (eg, what they can tell us about the age or the habitat or the climate or relationships of specimens, or anything else special about them)	
<b>Pictorial aids:</b>	6
Competitors could use any of the following – maps, photographs, drawings, time-lines, geological sections or diagrams.	
Average material may need more (and relevant) information than rare quality specimens	
<b>Presentation or fossil preparation:</b>	10
Competitors who have cleaned and prepared their fossils may choose to label their entry "Fossils cleaned by competitor" and be marked on that. Competitors entering fossils they have not prepared will be marked on the effort put into their presentation and research to make an eye-catching display	
<b>TOTAL</b>	<b><u>100</u></b>

**SECTION V – FOSSILS**

Each Class – one to ten specimens

		<u>Space Allocation</u>
<b>Class 81</b>	NZ fossils	Half or Full Cabinet
<b>Class 82</b>	Overseas fossils	Half or Full Cabinet
<b>Class 83</b>	NZ and overseas fossils	Half or Full Cabinet



## DIVISION FIVE: NOVICE

This Division is for those new to competition who do not wish to enter into the open classes. After winning first prize in any of the Novice Classes the competitor would not be eligible to enter as a novice in that particular class in subsequent competitions. All entries will be placed on a background of plain white fabric. This requirement does not preclude the use of stands used only to display specimens (Classes 84 & 85). This concession will ensure entries of colouring similar to the background material need not be disadvantaged. Competitors may use other backgrounds and display materials (Class 86).

### **Tumbled Stones**

Material to be used for tumbled stones can be natural or hammer broken, then tumble ground and polished. No specimen should be able to pass through a 20mm diameter hole.

#### Points Allocation

Aesthetic appeal	10
Polish	25
Freedom from pits and surface scratches	20
Freedom from flaws and cracks	20
Variety of material	10
Difficulty of material	10
Labelling	<u>5</u>
<b>TOTAL</b>	<b><u>100</u></b>

### **Cabochon**

Standard cabochon is to be made by hand with no mechanical aids other than the standard templates (refer to "Standard Cabochon" definition in Section C *page 12*).

#### Points Allocation

<b>Dome:</b> Polish	15
Girdle	5
Flats and scratches	10
Pits and fractures	10
<b>Back:</b> Polish	15
Bevel	5
Scratches, pits and fractures	5
Aesthetic appeal	5
Symmetry	15
Difficulty of material	10
Labelling	<u>5</u>
<b>TOTAL</b>	<b><u>100</u></b>

### **Mineral**

Specimen must be the competitor's own and must be too large to fit into a 30mm cube but must be small enough to fit into an 80mm cube.

Points Allocation (as specified in Sections Q-U *page 29*)

**SECTION W – NOVICE**

Class 84 – five specimens

Classes 85 &amp; 86 – one specimen

**Class 84** Tumbled stones, any origin**Class 85** Standard cabochon, any size, any origin**Class 86** Mineral, miniature handsized, any originSpace Allocation

200mm x 200mm

200mm x 200mm

200mm x 200mm

## DIVISION SIX: EDUCATIONAL CASE

Competition is for individuals and the showcase must tell a story and have an educational content.

### **Educational and Story Content**

Would a viewer who is unable to read be able to look at the case and understand the story? Is the written information correct, relevant and neat, so that it enhances the self-telling story? Main facts should be covered in a clear sequence. Labels should be attractive and easy to read. Language should be precise and to the point (“too little” and “too much” information are both points to be avoided). Written information should relate to the display objects and vice versa.

### **Presentation of Materials**

An essential feature of all displays is the initial impact on the viewer that makes you want to see what it contains. Does it draw you to the case? Points awarded are concerned with the initial attraction to the viewer.

### **General Attraction**

Does attractive material, skilful work, unusual materials or absorbing information keep the viewer there?

### **Originality of Idea and Skill**

Think up a good story, make it simple and uncluttered. Points are available for good design, placement skills, and preparation eg, a case of fossils, skilfully prepared, should gain some credit over a case of unprepared fossils, regardless of other features.

**Note** Please specify on Entry Form whether half or full cabinet required.

### Points Allocation

Educational and story content	60
Presentation of materials	15
General attraction	15
Originality of idea and skills	<u>10</u>
TOTAL	<u>100</u>

**SECTION X – EDUCATIONAL CASE**

**Class 87**    One entry

Space Allocation  
Half or Full Cabinet

## APPENDIX A – CABINET SPECIFICATIONS

The Show will use standard cabinets. The actual measurements are –

---

### APPENDIX A – CABINET SPECIFICATIONS

Edging around Glass 40mm

Timber thickness 12mm

Lights are inside cases

Internal dimensions Height 596mm Floor depth (front to back) 586mm

Width 1176mm Top depth (front to back) 103mm

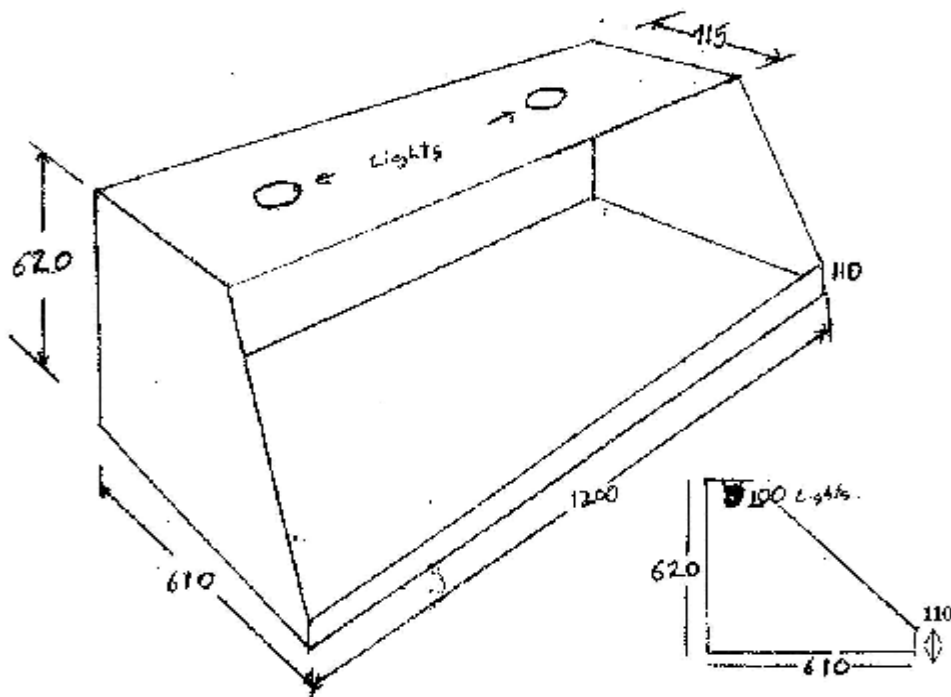

- (1) (a) for Interclub Showcase (Ken Allen Trophy)  
(b) for Fossils, Section U
- (2) Minerals, - Sections Q, R, S & T.

Showcases for Interclub measurements may vary by a few mm. We will supply exact measurements when the club entry arrives and allocate a showcase to that club.

The same for fossils and minerals.

These are average **inside** measurements taken over several cabinets. They may vary slightly with each cabinet. The lights are inside the top cover and come down into the cabinet 100 mm.

## **APPENDIX B – MINERAL BOOKS**

The following books are available at the time of judging –

**Fleischer's Glossary of Mineral Species (*Back & Mandarino*)**

**Dana's Manual of Mineralogy 17<sup>th</sup> Edition (Hurlbut)**

**APPENDIX C – DIAGRAMMATIC REPRESENTATION  
OF A STANDARD CABOCHON**

i) Without setting bevel

b) With (optional) Setting bevel

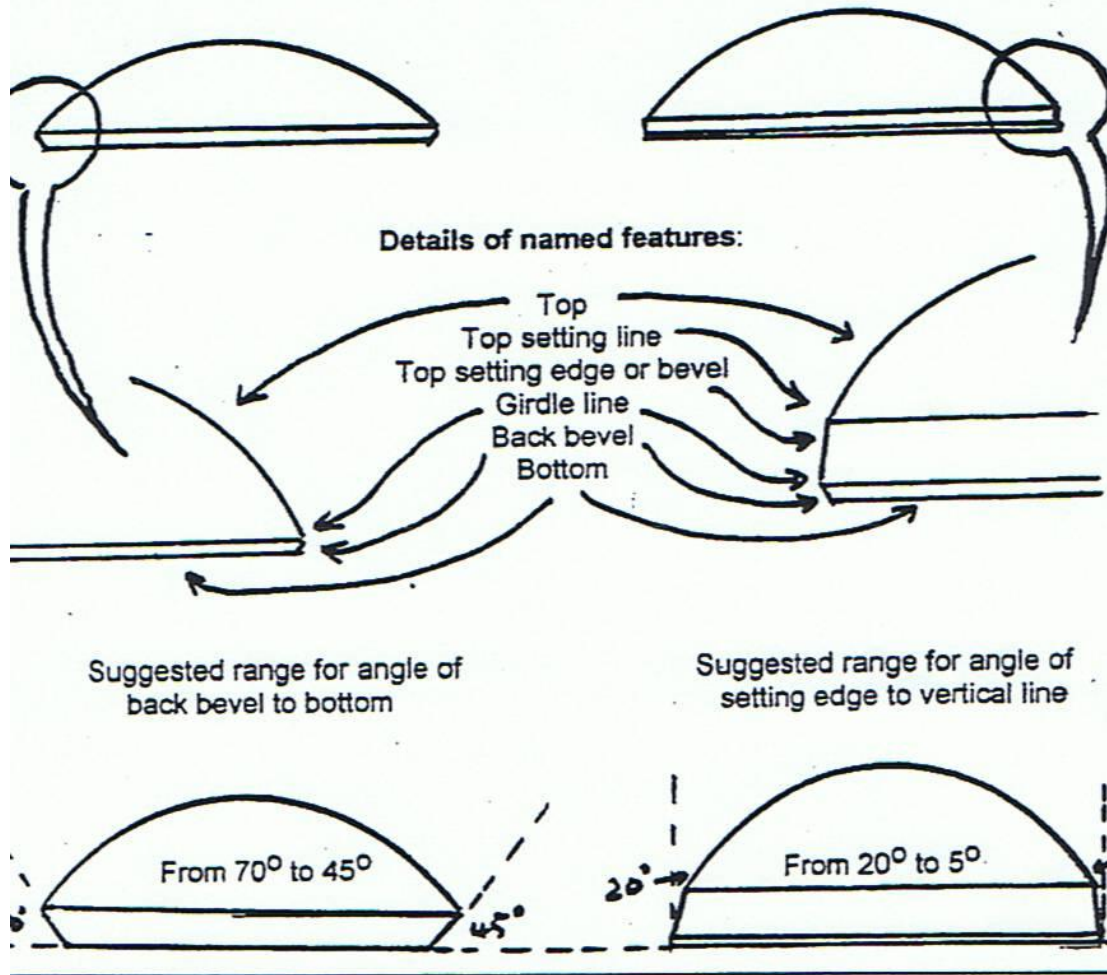

## APPENDIX D – FACETING DIAGRAMS

**Class 37: SRB, faceted girdle**  
**Material: Cubic Zirconia**

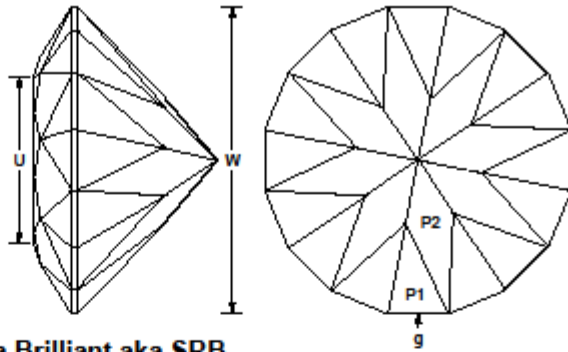
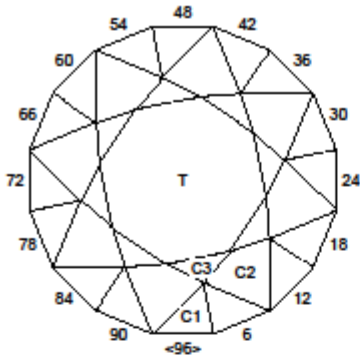

**Beta Brilliant aka SRB**

2008 USFG Single Stone Competition  
 PreMaster Stone  
 GemCad by Jeff Ford 2007  
 Angles for R.I. = 2.160  
 57 + 16 girdles = 73 facets  
 8-fold, mirror-image symmetry  
 96 index  
 $L/W = 1.000$   $T/W = 0.546$   $U/W = 0.546$   
 $P/W = 0.459$   $C/W = 0.123$   
 $Vol./W^3 = 0.202$

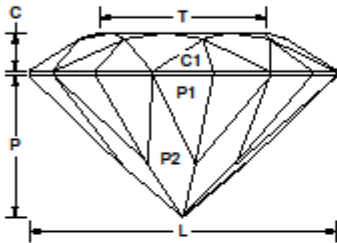

**PAVILION**

<b>g</b>	90.00°	96-06-12-18-24-30-36-42-48-54-60-66-72-78-84-90	cut to meet pb
<b>P1</b>	44.00°	96-06-12-18-24-30-36-42-48-54-60-66-72-78-84-90	
<b>P2</b>	42.00°	03-15-27-39-51-63-75-87	

**CROWN**

<b>C1</b>	32.00°	96-06-12-18-24-30-36-42-48-54-60-66-72-78-84-90
<b>C2</b>	28.00°	09-21-33-45-57-69-81-93
<b>C3</b>	13.00°	03-15-27-39-51-63-75-87
<b>T</b>	0.00°	Table

Material :Cubic Zirconia

Width: 11mm +/- .1mm

Girdle: .3mm +/- .1mm

C:\0-USFG\2008 SSC\1-Patterns\2-2008 SSC PreMaster.gem



**Class 38: Emerald Cut**  
**Material: Quartz**

**Emerald Cut**

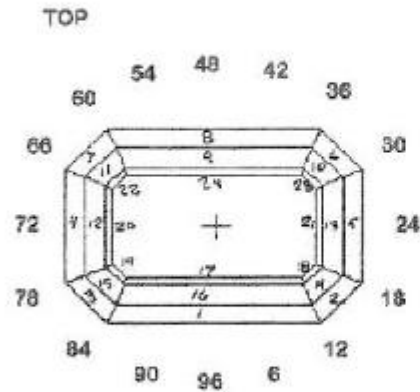

PC04002  
 Angles for R.I. = 1.54  
 45 facets + 8 facets on girdle = 53  
 2-fold, mirror-image symmetry  
 96 index  
 $L/W = 1.500$   $T/W = 1.026$   $T/L = 0.984$   
 $P/W = 0.672$   $C/W = 0.278$   
 $H/W = (P+C)/W = 0.950$   
 $PH = 0.693$   $C/H = 0.267$   
 $Vol. / W^3 = 0.784$

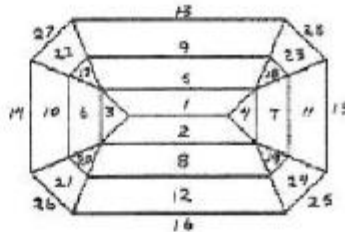
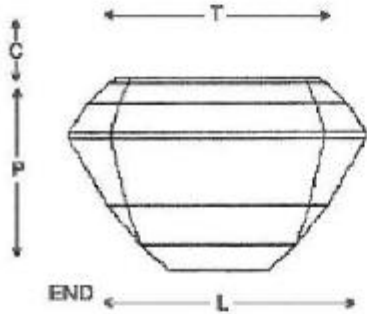
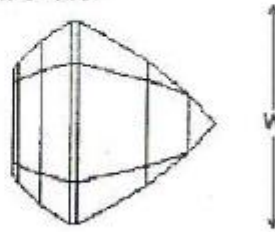

GROWN

BOTTOM

STEP	ANGLE	INDEX
1-8	58	96-48
2-3-9-7	58	12-84-36-60
4-5	58	72-24
9-16	45	48-96
10-11-14-15	45	36-60-12-84
12-13	45	72-24
17-24	30	90-48
18-19-22-23	30	12-84-80-36
20-21	30	72-24
Table	0	-----

**Class 39: 8 sided**  
**Material: Garnet**

Class 39: Garnet

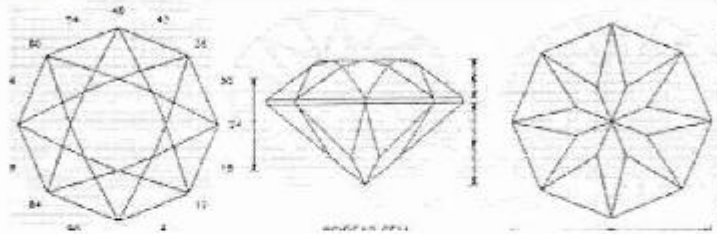

Angles for R.I. = 1.75      96 index

**PAVILION**

P1	90.0	06-18-30-42-54-66-78-90
P2	45.0	06-30-54-78
	45.0	18-42-66-90
P3	40.0	96-12-24-36-48-60-72-84

**CROWN**

C1	46.0	06-18-30-42-54-66-78-90
C2	37.0	96-12-24-36-48-60-72-84
C3	20.0	06-18-30-42-54-66-78-90
C4	0.0	Table

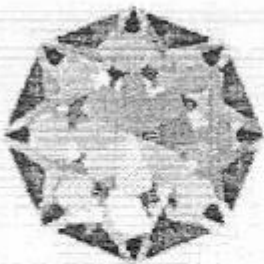
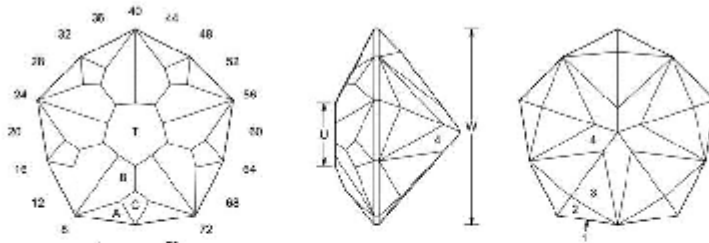

Figure 5.2 Brightness plot of 8 sided brilliant.  
 (Computer generated using GemRay)

## Class 40: Modified - Fiorello Cut

Material: Quartz



### fiorello\_80

Marco Volatini

Angles for R.I. = 1.540

51 + 10 girdles = 61 facets

5-fold, mirror-image symmetry

80 index

LW = 1.000 TW = 0.326 UW = 0.318

P/W = 0.420 CW = 0.201

Vol./W<sup>3</sup> = 0.202

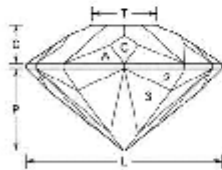

#### PAVILION

1	90.00°	02-14-18-30-34- 48-50-62-66-78	Set stone size
2	47.04°	02-14-18-30-34- 48-50-62-66-78	Temp Cer/Ter/Point
3	42.00°	01-15-17-31-33- 47-49-63-65-79	*
4	41.50°	80-16-32-48-64	CTP

#### CROWN

A	42.28°	02-14-18-30-34- 48-50-62-66-78	Set girdle thickness
D	28.00°	07-09-23-25-09- 41-55-57-71-73	Meet girdle, A
C	39.15°	80-16-32-48-64	Meet girdle, A
T	0.00°	Table	Floating table

For quartz and higher RI's

**Class 41: Fancy – Parklane Cut**

**Material: Topaz**

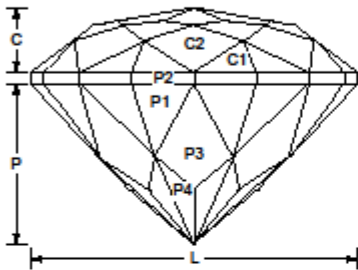
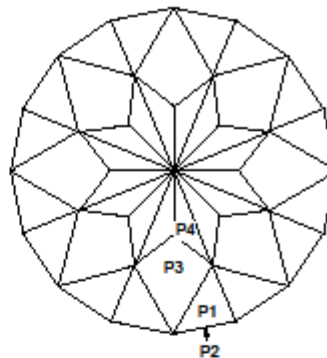
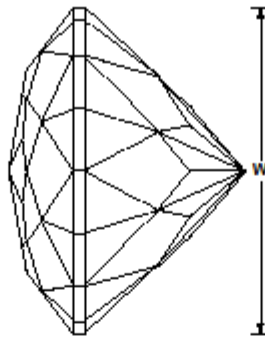
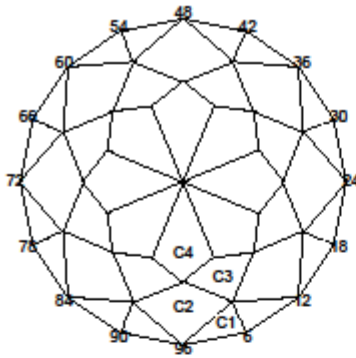

**Park Lane Cut**

Designed by Kel Smith (A.F.G.) 26th Jan 1997

Computer work by John Wren (A.F.G.)

Angles for R.I. = 1.63 (Topaz)

Angles for R.I. = 1.630

80 + 16 girdles = 96 facets

8-fold, mirror-image symmetry

96 index

L/W = 1.000

P/W = 0.493 C/W = 0.200

Vol./W<sup>3</sup> = 0.250

**PAVILION**

P1	51.00°	03-09-15-21- 27-33-39-45- 51-57-63-69- 75-81-87-93	Cut to TCP.
P2	90.00°	03-09-15-21- 27-33-39-45- 51-57-63-69- 75-81-87-93	Establish size of stone & level girdle
P3	47.00°	96-12-24-36- 48-60-72-84	Meet P1, P1, P2, P2 & create new TCP
P4	41.00°	03-09-15-21- 27-33-39-45- 51-57-63-69- 75-81-87-93	Meet P1, P1, P3, P3 & create PCP

**CROWN**

C1	45.00°	03-09-15-21- 27-33-39-45- 51-57-63-69- 75-81-87-93	Establish girdle thickness & level
C2	37.00°	96-12-24-36- 48-60-72-84	Meet C1, C1, P2, P2
C3	22.00°	06-18-30-42- 54-66-78-90	Meet C1, C1, C2, C2
C4	10.00°	96-12-24-36- 48-60-72-84	Meet C2, C3, C3

**INTERNATIONAL FACETING CHALLENGE 2000**

Section C

The specified size stone, to be cut in coloured CZ

Size to be 10.00 +/-0.1mm without penalty, across flats

C:\STONEGRAPHICS\GemCad\Parklane.gem